

# MICRO LIM™

Hybrid Servo-Pneumatic  
Liquid Injection Molding Machine

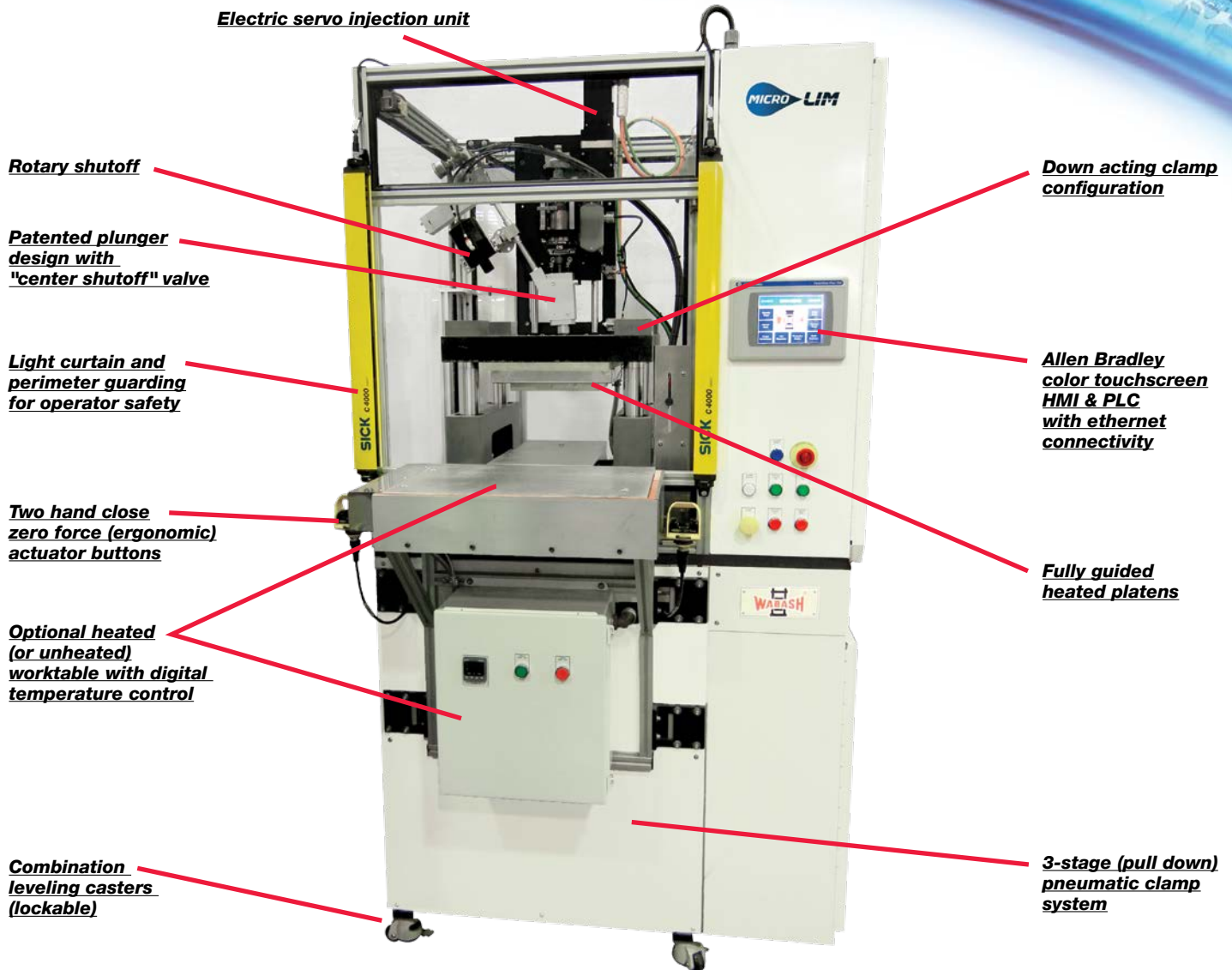

**Ideal for clean room and medical applications**, the hybrid servo-pneumatic MICROLIM™ Liquid Injection Molding Machine is designed for shot sizes from less than 1cc to 15cc. The MICROLIM features clamp force up to 17 tons and accurate shot size control from a patented plunger design with "center shutoff" nozzle.

- Clamp force: 17 tons
- Shot sizes from less than 1cc to 15cc and excellent repeatability
- Patented plunger design with "center shutoff" nozzle
- Servo driven
- Up to 150 recipes
- Easy to set-up and operate
- No hydraulics

*Ideal for short run applications* ■ *Easy changeover & cleanout*

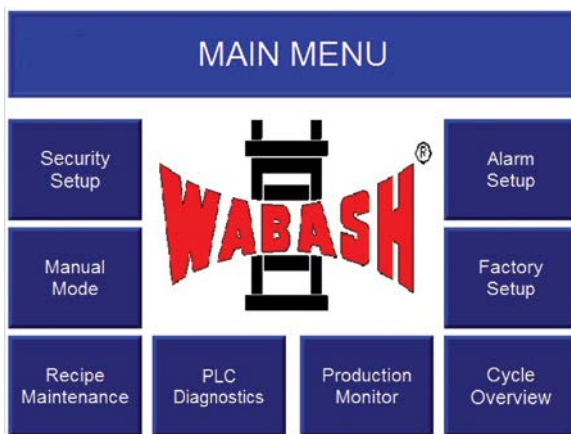
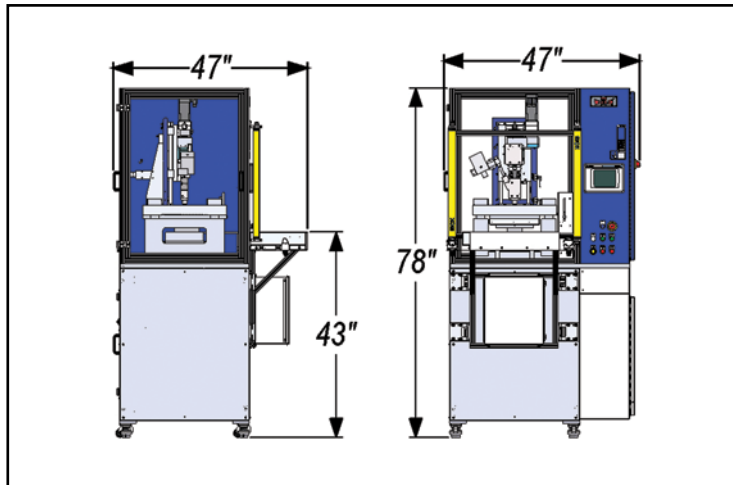

**Control of:**

- Shot size
- Injection speed
- Injection velocity
- Injection pressure
- Clamp pressure
- Platen Temperature

**Features:**

- Allen Bradley color HMI and PLC touchscreen
- Easy to navigate, menu driven screens
- Storage of up to 150 recipes
- Ethernet compatible
- “Off the shelf” electrical & pneumatic components for easy sourcing

- 5" clamp stroke
- 17 ton maximum clamp force
- 9" x 9" electrically heated platens (variable setting through user interface)
- 400°F maximum platen temperature



**WABASH MPI**

1569 Morris St., P.O. Box 298  
 Wabash, IN 46992-0298 U.S.A.  
 Phone: 260-563-1184 • Fax: 260-563-1396  
 E-mail: wabashmpi@acscorporate.com  
[www.wabashmpi.com](http://www.wabashmpi.com)



ISO 9001:2008 Certified

*All new Wabash presses are manufactured in compliance with current regulations and are furnished with safety guards as standard equipment. Guards may have been removed in some photographs for clarity. Wabash strongly recommends use of guards and personal protection equipment when operating any press. As a result of continuous improvement, specifications are subject to change without notice. Consult factory for specific data and pricing.*